

K-12 Internetworking Guidelines

Status Of This Memo

This memo provides information for the Internet community. This memo does not specify an Internet standard of any kind. Distribution of this memo is unlimited.

I. Introduction

Many organizations concerned with K-12 educational issues and the planning for the use of technology recognize the value of data communications throughout the educational system. State sponsored documents such as the California Department of Education's "Strategic Plan for Information Technology" recommend the planning of voice, video and data networks to support learning and educational administration, but they do not provide specific technical direction.

The institutions that built the Internet and connected early in its development are early adopters of technology, with technical staff dedicated to the planning for and implementation of leading edge technology. The K-12 community traditionally has not had this level of staffing available for telecommunications planning. This document is intended to bridge that gap and provides a recommended technical direction, an introduction to the role the Internet now plays in K-12 education and technical guidelines for building a campus data communications infrastructure that provides internetworking services and connections to the Internet.

For a more general introduction to the Internet and its applications and uses, the reader is referred to any of the references listed in the following RFCs:

- 1392 "Internet Users' Glossary" (also FYI 18)
- 1432 "Recent Internet Books"
- 1462 "What is the Internet" (also FYI 20)
- 1463 "Introducing the Internet - A Short Bibliography of Introductory Internetworking Readings for the Network Novice" (also FYI 19)

II. Rationale for the Use of Internet Protocols

In 1993, the Bank Street College of Education conducted a survey of 550 educators who are actively involved in using telecommunications. The survey looked at a wide variety of ways telecommunications technology is used in K-12 education. Their findings on Internet usage are summarized below¹.

"Slightly less than half of these educators have access to the Internet, which is supplied most frequently by a university computer or educational service.

"Internet services are used almost twice as often for professional activities as for student learning activities."

"Sending e-mail is the most common use of the Internet, followed by accessing news and bulletin boards and gaining access to remote computers."

The following chart shows the percentage of respondents that use each network application to support professional and student activities.

Applications	Professional Activities	Student Activities
Electronic mail	91	79
News or bulletin board	63	50
Remote access to other computers	48	32
Database access	36	31
File transfer	34	19

The value of the Internet and its explosive growth are a direct result of the computer communications technology used on the network. The same network design principals and computer communications protocols (TCP/IP) used on the Internet can be used within a school district to build campuswide networks. This is standard practice within higher education, and increasingly in K-12 schools as well. The benefits of the TCP/IP protocols are listed below.

Ubiquity TCP/IP is available on most, if not all, of the computing platforms likely to be important for instructional or administrative purposes. TCP/IP is available for the IBM compatible personal computers (PCs) running DOS or Windows and all versions of the Apple Macintosh. TCP/IP is standard on all UNIX-based systems and workstations and most mainframe computers.

Applications TCP/IP supports many applications including, but not limited to, electronic mail, file transfer, interactive remote host access, database access, file sharing and access to networked information resources. Programming and development expertise is available from a wide variety of sources.

¹Honey, Margaret, Henriquez, Andres, "Telecommunications and K-12 Educators: Findings from a National Survey," Bank Street College of Education, New York, NY, 1993.

- Flexibility** TCP/IP is flexible, and new data transport requirements can be incorporated easily. It can accommodate educational and administrative applications equally well so that one set of network cabling and one communications system may be used in both the classroom and the office.
- Simplicity** TCP/IP is simple enough to run on low-end computing platforms such as the Apple MacIntosh and PCs while still providing efficient support for large minicomputer and mainframe computing platforms. TCP/IP benefits from over twenty years of refinement that has resulted in a large and technically sophisticated environment.
- Capacity** TCP/IP supports local area network and wide area network services within the entire range of network data rates available today, from dial-up modem speeds to gigabit speed experimental networks. Communications can occur reliably among machines across this entire range of speeds.
- Coexistence** TCP/IP can coexist successfully with other networking architectures. It is likely that offices and classrooms that already have networks may be using something other than TCP/IP. Networks of Apple Macintosh computers will probably be using Appletalk; networks of PCs may be using any of the common network operating systems such as Novell Netware or LANManager. Mainframe computers may be using IBM's System Network Architecture (SNA). None of these proprietary protocols provides broad connectivity on a global scale. Recognizing this, network technology vendors now provide many means for building networks in which all of these protocols can co-exist.
- Multimedia** TCP/IP networks can support voice, graphics and video as part of teleconferencing and multimedia applications.
- Compatibility** All of the major Universities, as well as thousands of commercial and governmental organizations use TCP/IP for their primary communications services. Commercial networks such as CompuServe and America Online are also connected to the Internet. Many State Departments of Education have sponsored statewide initiatives to connect schools to the Internet and many K-12 school districts have connected based upon local needs.
- NREN** The High Performance Computing Act of 1991 and the Information Infrastructure and Technology Act of 1992 provide the foundation for building the national telecommunications infrastructure in support of education and research. The National Research and Education Network (NREN) will be based upon Internet technology.

The benefits of internetworking technology have been demonstrated through twenty years of use by thousands of organizations. This same experience also

provides tested technical models for network design that can be adapted to K-12 campuswide networking in schools of all sizes and technical development.

III. A Technical Model for School Networks

The vision of a modern communications network serving all primary and secondary schools has been articulated and discussed in many forums. Many schools and a few school districts have implemented *ad hoc* network systems in response to their own perception of the importance of this resource. This section of the Internet School Networking (ISN) Working Group RFC presents a standard network implementation model to assist county offices of education and school districts in their planning so that all such implementations will be compatible with each other and with national networking plans intended to enrich K-12 education.

The future goal of “an integrated voice, data, and video network extending to every classroom” is exciting, but so far from what exists today that the investment in time and dollars required to realize such a goal will be greater than most districts can muster in the near term. We suggest that a great deal can be done immediately, with relatively few dollars, to provide modern communications systems in and between all schools around the nation.

Our present goal is to define a highly functional, homogeneous, and well supported network system that could interconnect all K-12 schools and district, county, and statewide offices and that will enable teachers and administrators to begin to use new communications tools and network-based information resources. It takes considerable time to adapt curricula and other programs to take full advantage of new technology. Through the use of standard models for implementation of current network technologies, schools can begin this process now.

Many states have already developed communications services for their schools. A notable example is Texas which provides terminal access to central information resources from every classroom over a statewide network. Modem-accessible systems are available in many states that serve to encourage teachers to become familiar with network resources and capabilities. Although modem-access may be the only practical option today in some areas, it always will be limited in functionality and/or capacity. In anticipation of emerging and future bandwidth intensive information resource applications and the functionality that they will require, we believe it is essential to provide direct network access to the National Research and Education Network (NREN) Internet² from computers in every classroom.

The Internet communication protocols, commonly known as “TCP/IP,” are the “glue” that will allow all computers to communicate. As noted above, software that implements Internet protocols is available for all modern computers. These protocols support a very wide variety of applications, from

² The Internet is a “network of networks” that interconnects institutions of higher education, research labs, government agencies, and a rapidly growing number of technology and information vendors.

electronic messaging to client/server data access. The use of Internet protocols will ensure that all networked computers will have direct access to the vast range of existing information and education resources on the Internet, as well as to the emerging National Information Infrastructure.

Approach

The implementation we suggest would use current proven and cost effective technology and would be expandable and upgradable to newer technology with minimum additional investment. This approach requires careful, modular design to meet the following criteria:

- 1) Any physical infrastructure development should be general and flexible enough to be reused as technology improves. For example, a school office might have a simple terminal today which could be wired to a network adapter serving the school building. Later a Macintosh, DOS, or Windows-based PC might replace the terminal, and the type of connection to the network would change accordingly. However, the wiring between the office and the network "hub" site could remain the same if it is designed properly to begin with. This is an important consideration since wiring typically represents 20 to 40% of the cost of individual network hookups;
- 2) Existing computers and terminals in schools and district offices should be integrated as much as possible into the communication system. This installed base represents a large investment, albeit in many cases a somewhat dated set of equipment. Wholesale replacement of that base would be a large additional burden on funding resources.

A consequence of the above is that the user interface and the services available will vary depending on the type of equipment used to access the network. For example, DOS PC's, Macintosh computers, or Unix workstations would be connected directly to Local Area Networks (LANs) and would be provided with communications software to support a broad set of functions, many of which will have graphical user interfaces and will make use of client/server technology. Apple-II computers, "dumb" terminals, or other such devices could be connected to intelligent network hubs that would allow access to network server computers or information resources, but almost certainly will not support the full range of functionality provided by a direct network connection. In the short term, this is a limitation that we must accept;

- 3) Network servers will be located where they can be managed and supported, and also provide access paths with adequate bandwidth. A system of hierarchical servers should be created in larger school districts, with automatic transfer of common information from a central system to the secondary systems each night, or at appropriate intervals. Local servers will allow each school to provide on-line information particular to its programs and community. This model optimizes use of network bandwidth as well;
- 4) School interconnect topologies (links) must be both cost effective and manageable. Communication between schools, district offices, county offices of education, and the State Department of Education must be

reliable and of sufficient capacity to support the primary applications as well as allow development of new applications.

Capacity is measured both by total data traffic volume and by response time when information is requested over the network. Reliability is measured by the percentage of time that the network is able to transport data. Reliability should be well over 99.7%. Capacity should be such that no more than 10% of the communications bandwidth is used during a typical work day. This is intended to leave adequate capacity for good response time to short term communication demands.

Many schools already have some form of communications infrastructure in place. In some cases this infrastructure can be adapted to newer technologies; in other cases it may have to be replaced over time. These issues are explored further following presentation of the basic model that serves as a guideline for future communications system development.

Implementation Model

There is no one “blueprint” for a network that will drop into every school. Each school will have particular physical constraints, functional needs, an existing technology base, funding constraints, and opportunities for collaboration with vendors and support groups in its area. What is presented here is a set of general guidelines that can be followed in the planning of a school network implementation.

The strategic decision to use Internet protocols in developing school networks provides the opportunity to avoid the major expense of building new statewide backbone infrastructures in the near term. Interconnection of schools, districts, county offices of education and the State Department of Education can be accomplished by acquiring Internet connection service from any of the existing Internet service providers in the state³. It is critical that Internet connection service meet criteria for reliability and capacity but connection to any Internet service provider will provide communication capability to all other Internet subscribers within the state, the nation, and the world.

Internet technology is designed to allow very flexible intersite topologies, but a hierarchical topology is the simplest to engineer. Generally this will mean hierarchical connection of school facilities to district offices, in many cases further aggregated at county offices, and finally a link to an Internet service provider. Coordination of circuit services and a single point of connection to an Internet service provider serves both to minimize overall costs and increase opportunities to make use of newer technologies.

The basic school network implementation model is quite simple: create a local area network (LAN) within each school building or cluster of buildings, provide at least one network server for that LAN, interconnect that LAN with the local school district offices where a similar LAN should be installed and

³ “Connecting to the Internet”, Susan Estrada, O’Reilly & Associates, Inc. (ISBN 1-56592-061-9) lists Internet service providers in California and the nation.

where centrally managed information resources should exist, and connect the district offices to the nearest Internet service provider, possibly through the county office of education.

Primary technical support for network monitoring and problem resolution, and for managing network resource servers should come from the district or county offices initially to avoid unnecessary duplication at the local level. As expertise is developed at the local level, more of the responsibility for daily operation and problem resolution can be assumed by individual schools.

It is impossible to cover all conceivable scenarios for implementation of this model in specific schools. However, it is possible to state general principles that should be followed in designing school network implementations. The discussion below is organized into sections corresponding to the basic model summarized in the previous paragraph. It includes a description of the general principles that are important to each level of the implementation.

Step 1: School Local Area Network Implementation

A “school” is used here to mean a building or cluster of buildings that are managed as a unit and typically are on contiguous, district owned property. Implementation of a LAN in this setting will involve installation of a cabling system to distribute the network throughout the structure(s), installation of premise wiring to support connections of computers and terminals to the network distribution system, installation of one or more network server machines in a central location⁴, and provision of a network router and telecommunications circuit or radio link to connect that school to the district offices.

The most common LAN technologies in use today are ethernet and LocalTalk⁵. Both are quite inexpensive and easy to install and maintain. Ethernet is adaptable to most modern computers and is built-in to high performance workstations such as Sun, Hewlett-Packard, SGI, or Digital Equipment Corporation computers. LocalTalk is built-in to all Macintosh computers and is adaptable to DOS PC computers as well. Ethernet is roughly 20 to 40 times faster than LocalTalk. Therefore ethernet is recommended for all computer connections, when possible, and for the school LAN “backbone” or network distribution system.

1.1 Network Adapters and Software

Individual computers will require network or communications adapters and appropriate software. Table 1 gives basic recommendations for the computers most commonly found in schools. Basic communications software is available in the public domain for many personal computers at no cost. More sophisticated software is being developed by a number of vendors for applications such as electronic mail, distance learning, and multimedia

⁴ Other protocols, such as AppleTalk or Novell’s IPX, may be supported on a school’s local area network (LAN) as needed for local functions such as printer sharing or local resource servers.

⁵ IEEE 802.5 Token Ring is not recommended for new installations. It is more expensive and it is not available for as wide a range of computers.

database access. For example, the California Technology Project is developing very easy to use software for Macintosh and DOS or Windows PC computers that will enable access to a wide variety of information resources and services. Schools should look at all the available software and base choices on required functionality and support costs as well as acquisition costs.

Equipment Type	Network Adapter	Communication Software
Simple terminal	“Network Access Server” located centrally.	Built-in to the network access server.
Apple II, Amiga, Tandy, Commodore, older IBM PC’s, etc.	Serial asynchronous port that will allow connection to the above.	Serial communications software that emulates a simple terminal.
Newer IBM PC’s	Ethernet adapter card with “10-base-T” port. “Thin-net” port may be used in lab clusters.	TCP/IP “TSR” software, for example “FTP Software” package. Additional software for special appl.
Older Apple Macintosh computers	PhoneNet adapter (external) and shared LocalTalk to ethernet router, for example the Shiva FastPath.	MacTCP or equivalent plus “telnet” and “ftp”. For example, NCSA Telnet. Additional software for special applications, eg. “electronic mail client.”
Newer Apple Macintosh computers	May use same as the above. For higher performance, use an ethernet adapter card with “10-base-T port. “Thin-net” port may be used in lab clusters.	Same as the above.
Unix workstations	Ethernet adapter card, if not already built in.	Typically comes with the basic system. Additional software may be needed for special applications.

Table 1: Network Adapters and Software for Typical Computers

In locations where computers will be purchased, the choice of computer type should be driven by the availability of software for the particular application(s) to be supported. Almost all modern computers can be attached to the type of network described in this document.

1.2 Premise wiring

A major component of the implementation will be installation of cabling to connect individual computers or clusters of computers to the LAN. The recommended topology is a “star” where each computer is wired directly to a “hub site” within the building as shown in Figures 1 & 2. A cluster of computers, typically found in a teaching lab or library, may be interconnected within the room where they are installed, and the cluster connected to the hub site with a single cable as shown in Figures 3 & 4.

The recommended premise wiring is “unshielded twisted pair” (UTP) wire that meets the Electronic Industries Association (EIA) category 5 standards for high speed data communication service⁶. While 2 pair cable may be adequate for most purposes, industry standards recommend installation of 4 pair cable. The difference in cost is minimal so we recommend installation of the latter. One end of each cable terminates in a category 5 RJ-45 jack⁷ located near the computer. The other end terminates on a standard “110 distribution block⁸” at the hub site utility closet. A labeling scheme must be chosen and strictly adhered to so that cables can be identified at both ends later, as needed.

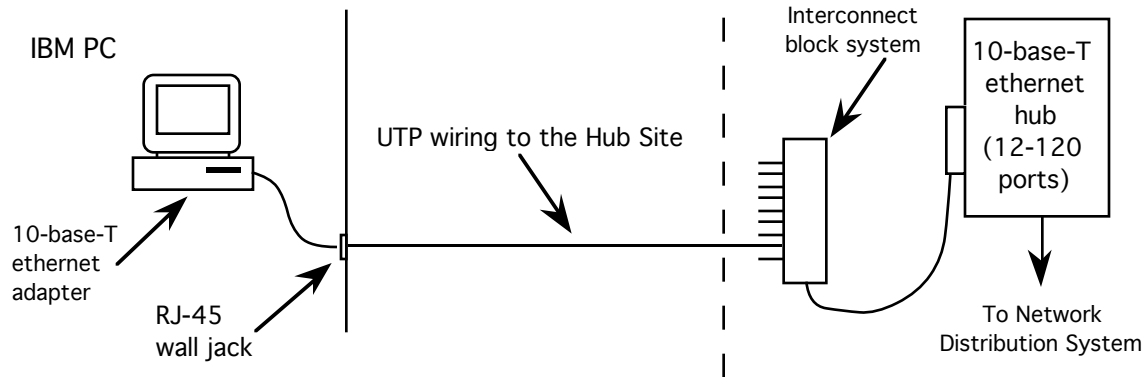

Figure 1: Individual ethernet connection to the network

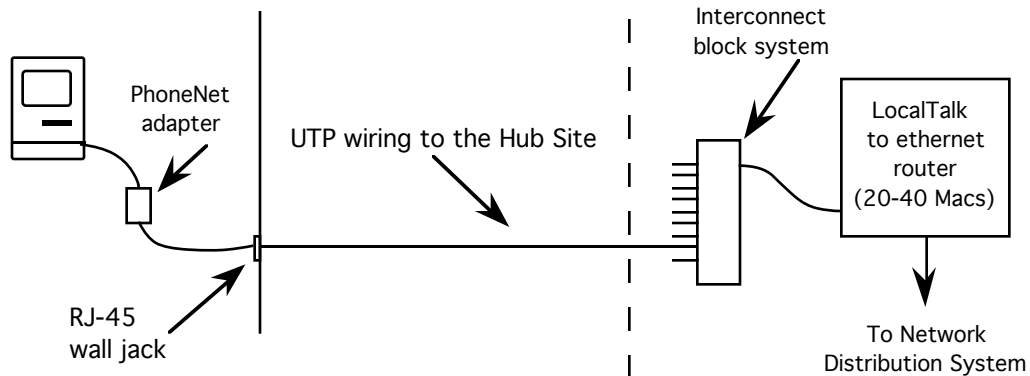

Figure 2: LocalTalk connection to the network

In most cases, the hub site utility closet will be shared with telephone services. It is essential that a separate wall area be set aside within the closet for data service interconnections. Typically there will be a “field” of

⁶ See EIA/TIA-568 “Commercial Building Telecommunications Wiring Standard.”

⁷ A standard RJ45 jack can be used for ethernet or lower speeds if initial cost is a major factor. Such jacks can be replaced with category 5 versions later as needed.

⁸ In older sites, M66 distribution blocks may already be installed. These can be used for the time being but will not support newer higher speed technologies.

interconnect blocks for termination of all premise wires, another field for termination of trunk cables (used for low speed data terminals), and a third field for hub equipment ports. Interconnections between premise wiring blocks and hub or trunk blocks are installed as needed in order to provide the appropriate service to each location where communication service is required.

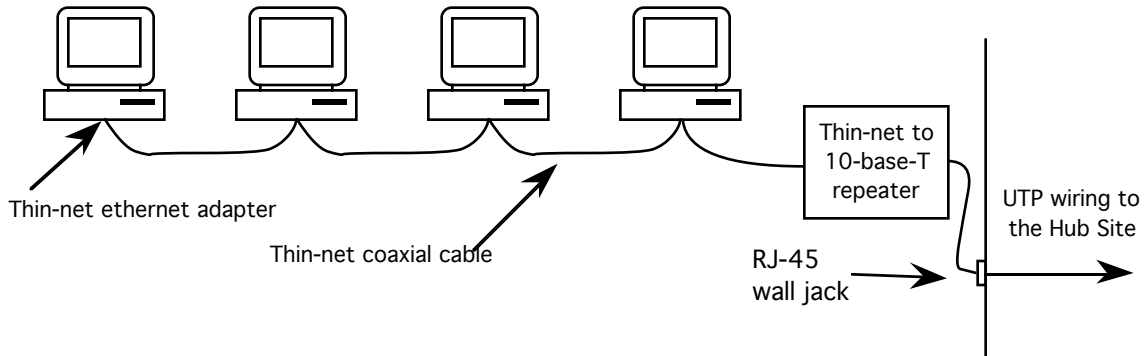

Figure 3: A cluster of computers connected to the network

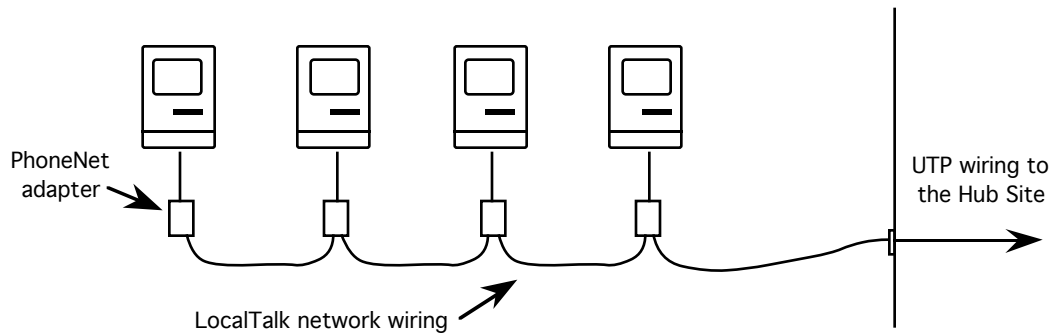

Figure 4: A Macintosh cluster connection to the network

Installation of wiring in a building typically is performed by a qualified data wiring contractor. This is a critical aspect of the program and must be planned and installed professionally with both current and future requirements in mind⁹. To be prepared for future distribution of video signals, school network planners should consider installation of RG-59 coaxial cable to those locations where video may be required at the same time that the UTP premise wiring is being installed. The coaxial cable would terminate on a wall plate mounted "F" connector in the classroom, and would be left unterminated in the utility closet. Future technologies may support video signals over other media so the installation of RG-59 cable should be limited to near term potential requirements.

⁹ See "Virtual Schoolhouse - A Report to the Legislature on Distribution Infrastructures for Advanced Technologies in the Construction of New Schools, K through 12" (Department of General Services, State of California, Feb 1993) for example conduit and utility closet plans.

It will be cost effective to install premise wiring to as many locations as might ever serve a computer. This will include administrative offices as well as classrooms, laboratories as well as libraries. In high density locations such as offices, consideration should be given to installation of two UTP cables to each outlet location in order to provide the potential for several computers or workstations. Terminating both cables on the same wall plate will add little to the overall wiring project costs and will add greatly to the flexibility of the system. Premise wiring that is not to be used initially will not be connected to any electronics in the hub site.

Hub sites should be utility closets or other protected, non-occupied areas. Hub sites can be created by construction of small closets or cabinets in low use areas. A hub site must be located within 300 feet of any connection. Typically, multiple hub sites are required in large or multi-story buildings.

1.3 Network Distribution System

All hub sites within a school must be interconnected to complete the school LAN. The design of this network distribution system will depend greatly on the physical layout of the school buildings. We assume that ethernet technology will be used since higher speed technology is still quite expensive.

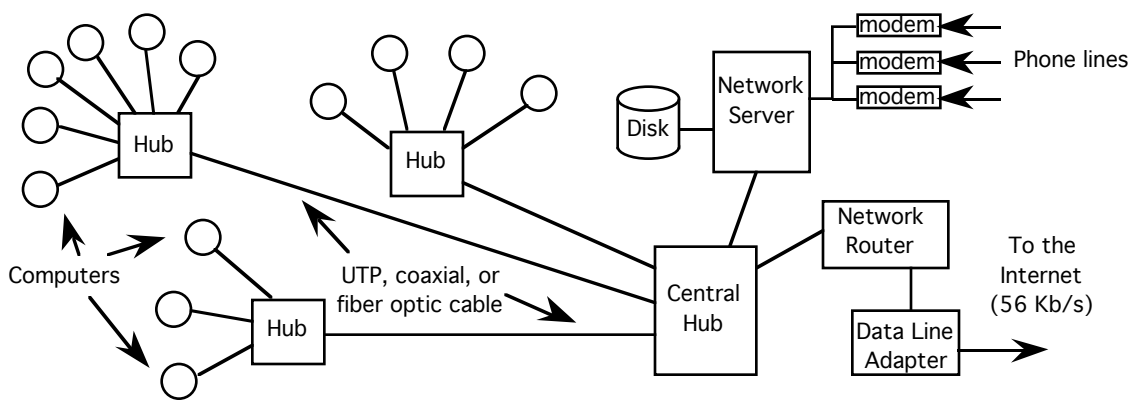

Figure 5: A complete small school LAN

If all hub sites are within 300 cable feet of a central location, then 10-base-T wiring can be used from a central hub to connect each hub site, as shown in Figure 5. If longer distances are required, either thin-net or standard thick ethernet can be used. Fiber optic cable can be used if distance requires it and funding permits¹⁰. Specific design of the “backbone” network distribution system will depend on the layout of the buildings to be served.

With proper design as many as 250 computers can be connected to a single ethernet segment. Most often the practical maximum number will be much lower than this due to the amount of data sent onto the network by each

¹⁰ If fiber optic cable is installed, consideration should be given to including both multimode fiber for current and future data requirements and single mode fiber for video and future very high speed data systems.

computer. For planning purposes, one can assume 100-125 computers per segment. Beyond that size the network must be subdivided using "subnetworks." Design of a such a system is not difficult, but is beyond the scope of this document.

The network distribution system cabling should include unshielded multi-pair trunk cabling as well as ethernet trunk cabling. The multi-pair trunk cable will be needed to connect terminals or older computers emulating terminals to a central "network access server" (NAS). A typical NAS can serve from 8 to 128 such connections. It is most cost effective to provide one per LAN, if needed. The NAS connects directly to the ethernet LAN.

1.4 Local Network Server

It is highly recommended that each school install a "network server" to support local storage of commonly used information, software, electronic mail, and other functions that may require high speed communication to the user's computer. Since the connection to the outside network will be much slower than the school LAN, it will be most efficient to access information locally. In particular, software that is to be shared among the school's computers must be stored locally since it would be very tedious to transfer it across the slower external link. The network server will be connected directly to the ethernet network.

The location of the server should be chosen carefully to ensure its protection from abuse and environmental damage. Traditionally the school library is the focus of information gathering and storage activities and many school libraries have clusters of computers or terminals already installed. The library would be a very logical place to locate the network server computer. The Network Router (see below) might also be located there if a suitable utility space is not available.

The network server will be a small but powerful computer with a large amount of disk storage capacity, typically 1-4 gigabytes. It will run software capable of supporting access by a large number of users simultaneously. It could also support dial-in access from teacher's or student's homes using standard inexpensive modems¹¹. If more than a few modems are to be installed, a NAS might prove more cost effective. If dial-in access is to be provided to more than a few school sites within a district, a single central modem pool maintained at the district offices will be the most cost effective.

1.5 External Connection

A single communication circuit will connect the school LAN to the local school district offices. In the school, there will be a Network Router attached between the LAN and this circuit. On the LAN side, the connection will be a typical ethernet cable. On the external side, the connection will depend on the type of communication circuit used, as discussed in step 2 below.

¹¹ Access control with user authentication is essential if dial-in service is to be provided.

Step 2: Interconnection of Schools with District Offices

All schools within a district should be connected individually to the network router at the school district offices. This “star topology” will be much easier to manage and the capacity of each school’s connection can be increased appropriately as needs change.

Several standard communication circuit services may be used to effect this connection. The least expensive for situations where only limited use is needed will be dial-up using high speed modems. However, this type of connection is not recommended for serious usage due to its very limited capacity. Also, since most schools receive telephone service under business tariffs, usage will be measured and the cost will be dependent on how long the connection is maintained. This will be true in general for other “switched services” as well such as “switched-56” and ISDN. Dedicated (permanently installed) communications circuits are strongly recommended since they will allow unattended access to and from the school network at all hours. This will be particularly important if information files are to be down-loaded during the night to local network servers or teachers and students are to access the school’s information resources from home.

Table 2 shows the most common options for dedicated circuit services. Costs are indicated in relative terms since they vary greatly by location and as tariffs are modified. The exact costs must be determined by contacting local communications service providers. Total cost must take into account the equipment needed at each location as well.

Type of Circuit	Data Rate	Relative cost
Voice grade leased telephone line	20 kilobits per sec (Kb/s)	modest ¹²
ADN-56	56 Kb/s	high
ISDN, where available	64 or 128 Kb/s	modest ¹³
Low power radio	64 to 256 Kb/s	high startup cost
Frame Relay	56 Kb/s to 1.5 Mb/s	modest to high
DS1	1.5 megabits per second	very high

Table 2: External Connection Communications Options

Frame Relay communication services are becoming available in many areas. Frame Relay is a shared, packet based data transport service. A school site would contract for Frame Relay service as part of a larger service group that includes the school district office and may include the Internet service provider. All members of that group would share the communications capacity. The advantage of this service is that only one end of the circuit needs to be ordered (each member orders a connection to the common service) and the capacity offered to each member can be upgraded independently. Also, in many areas the cost of Frame Relay service is not dependent on distance to the service provider which will make service to

¹² Measured service charges must be taken into account.

¹³ At this time, most ISDN tariffs include message unit charges which can make the use of ISDN prohibitively expensive for full-time connectivity.

rural schools much less expensive than equivalent services. Overall system costs will be minimized since the central router at the district office will need fewer connections.

If Frame Relay is chosen, the overall service group must be carefully engineered. For example, since all schools would share the connection to the district office (and possibly to the Internet service provider), that must be a high capacity connection. For the initial design, the aggregate capacity of all school links should not exceed the capacity into the district office (or the Internet service provider) by more than a factor of 3 or there may be noticeable congestion and variability in response times across the system. There are many other factors that must be considered as well, such as the virtual connection topology and how best to connect to an Internet service provider. Therefore, it is recommended that an experienced network engineer be utilized to develop an operational plan for Frame Relay if it is chosen as the school interconnection service.

Future options for interconnecting schools and district offices will include¹⁴:

- Community Access Television (CATV) cable systems offering either shared or dedicated bi-directional data communication services,
- metropolitan area fiber optic communications service providers,
- Switched Multi-megabit Digital Service (SMDS) providing data transport service at speeds up to 34 megabits per second.
- Asynchronous Transfer Mode (ATM) connection services supporting voice, data, and video communications at speeds into the gigabit per second range.

The costs for the last three options are unknown at this time, but may be generally higher than those indicated in Table 2. The cost for the CATV option may be negotiable as part of the local CATV contract with the community.

As demands for network speed develop due to heavy use of multimedia or other bandwidth intensive application, higher speed communications circuits can replace the initial circuits with minimal change in the equipment or LAN. This gives great flexibility in tailoring service to funding levels and application needs.

Step 3: School District Office LAN and Support Systems

The School District offices should form the focal point for interconnection of all schools in the district. Within the District offices, network operations can be monitored and problem resolution managed. One or more network servers can provide essential network support as well as central archiving of common information and software.

¹⁴ Many more options will become available as new technologies come to market.

A critical role of the district office will be to manage Internet “Domain Name System¹⁵” (DNS) service for the district’s schools. DNS is required of all Internet networks. It defines the basic network level identity of each computer, workstation, server, and active network component. This function is described more fully below under Network Management and Operational Monitoring.

The district offices should be wired in a manner similar to a typical school, as shown above. This will allow teachers, superintendents, and principals to communicate and share information easily. In addition, an NAS connected to a central pool of modems could provide dial-in access to the district network.

Step 4: Interconnection of the School District with the Internet

Connection of the entire school district to the Internet will take place through the district office interconnect site, as shown in Figure 6. This hierarchical model can be extended another level to interconnection of the school district offices through the county office of education facilities. Many administrative information resources could be located at the county level, and there might be cost savings if the entire county connects to an Internet service provider through a single point. The bandwidth required for this single connection, however, will be much greater than that required for each school district since traffic will be aggregated.

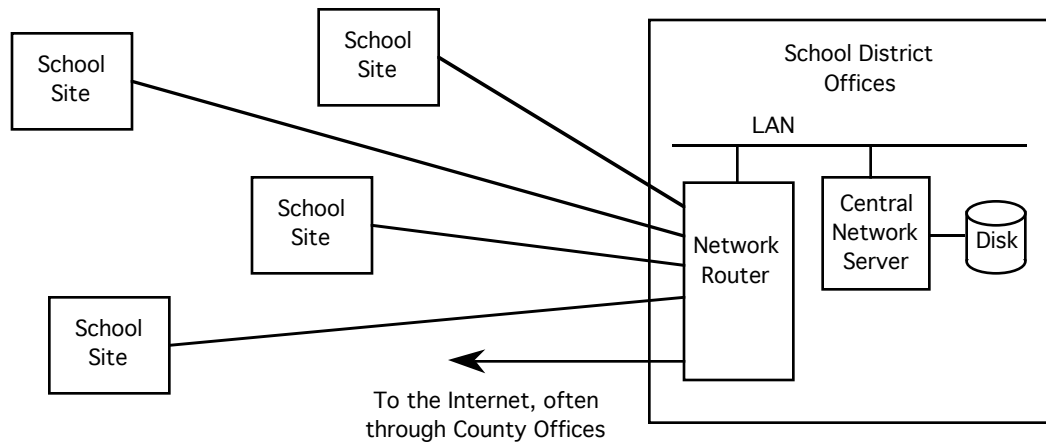

Figure 6: Interconnection of schools to the Internet through local School District Offices

This hierarchical topology also provides a logical model for network support and information resource management. The school district or county offices can provide continuous monitoring of the network and provide high level technical expertise for problem resolution, relieving the individual schools of this burden. Interactions with communications circuit providers and Internet service providers will be more effective if handled through a central “trouble

¹⁵ See STD 13, RFCs 1034 and 1035 for the full explanation of DNS, and also, RFC 1480.

desk.” Similarly, it is highly desirable that network users have a single, well known point of contact in case of problems or questions.

Internet service should be acquired from the most cost effective, reliable Internet service provider. Circuit services can be similar to those shown in Table 2 above. The higher speed services should be considered if traffic demands increase and funding permits. Circuit costs usually will be lowest when connecting to the provider with the nearest “point of presence” (POP), but newer technologies such as Frame Relay and SMDS¹⁶ make circuit costs less dependent on distance. The Internet connection will require a high quality router that can be configured to interact correctly with the service provider’s routers. In most cases, this can be the same router used to support the local school connections.

Integration of Existing School Networks

Many schools have developed LAN systems in support of particular classroom activities or administrative functions. In some cases the technologies used are not those recommended for new installations. If these older LAN systems are capable of transporting Internet protocols they may be integrated into a new LAN system and replaced later as funding permits.

For example, IEEE 802.5 Token Ring is often used to interconnect DOS PC-type computers and IBM minicomputer servers. Token Ring networks can transport Internet protocols and software is available for DOS computers to support basic Internet functions. Many Internet routers support optional Token Ring adapters. This is the recommended way that existing Token Ring LANs can be integrated into a wider school LAN system in order to extend Internet information resources to those PC users.

Another example is a Novell Network system using ethernet as a LAN. The ethernet LAN, if implemented well, is perfectly capable of transporting Internet protocols as well as Novell protocols, simultaneously. Each PC or Macintosh can be given software that will allow both Novell and Internet services to be used as needed. This coexistence is important so that, for example, a person using a PC that depends on the Novell server for disk file space can transfer a large file from a remote Internet server to the PC’s pseudo-disk. It also permits each user to run client software such as Eudora (electronic mail), Gopher (information services), and Mosaic (World Wide Web information services) which require direct Internet access. To integrate the Novell ethernet LAN into the wider school LAN system a simple ethernet repeater can be used in a manner similar to Figure 3 above.

An alternative to supporting both protocols that is sometimes suggested in cases such as the one cited above in which a network server already exists is to use the server as a “network application gateway.” This approach is strongly discouraged. It is essential that each computer and workstation support Internet protocol data communication directly so that modern client/server applications can be supported where the server or servers may be located anywhere on the Internet. The “gateway” approach severely

¹⁶ At this time, SMDS services are not widely available.

restricts the workstation's potential ability to access multimedia and other important information resources.

Some technologies, such as "arcnet," may not be capable of supporting Internet protocols but may offer "terminal emulation" shared access to something like a "modem pool." The modem adapter might be rewired to connect to ports on a network access server instead. This would provide simple access to information resources for the arcnet users.

In any case, older LAN technologies should **not** be expanded and should be phased out as funding permits. It is critical that there be a relatively homogeneous installed base of technology in order that new applications of information resources can be provided to the entire school community.

Network Management and Operational Monitoring

All networks require some level of network management in order to ensure reliable service. Monitoring of the health of the network can help identify problems before they become detrimental to network users. It also can help predict trends in traffic patterns and volume.

Internet technology network management consists primarily of determining the proper routing parameters for optimal and reliable network operation, assignment of network Internet Protocol (IP) addresses and maintenance of a network-accessible database of node names corresponding to each address¹⁷, and monitoring the daily operation of the network. These functions typically are performed by the staff of a Network Operations Center (NOC).

Domain Name System

The Internet Domain Name System (DNS) is the mechanism for documenting and distributing information about the name and address of each computer attached to the network (network nodes). The DNS service is provided by software that runs on the main network server. It uses a database that is created and maintained by the NOC staff.

An Internet address is the numerical identifier for a node and it must be unique among all nodes associated with the network. Furthermore, if the network is to be part of the global Internet, all addresses must be legitimate within the worldwide Internet system.

Associated with each numerical address can be one or more "node names." Although computers have no difficulty using numerical addresses, it is often easier for computer users to remember and use the node names rather than the numerical addresses. In particular, electronic mail addresses use node names. DNS node names are hierarchical and by appropriately using this hierarchy "subdomains" can be assigned to each school site or district office. In this way, naming can be structured to be flexible as well as meaningful in the context of the whole organization.

¹⁷ See RFC 1480 for a discussion of Internet naming conventions for school networks.

A plan for the assignment of IP network addresses and node names should be developed early in the planning for the network installation. Initially, the database serving the DNS should reside on the “district server” so that there is one site at which all assignments are officially registered. As the network grows and expertise is developed, secondary DNS service can be run on the servers at larger school sites.

The main DNS server for the district should be located as close to the Internet connection (topologically) as possible. This proximity is to help ensure that network problems within the district network will have minimal impact on access to the server. This design is illustrated in Figure 1 where the district server is on an ethernet connected directly to the main distribution router.

Associated with the assignment of node names and addresses should be a database of specific information about the computers connected to the network. When trying to resolve problems or answer user questions, it is very important to know where the computers and other nodes are located, what type of computer and software are in use, and what type of network connection is installed. With proper software this database can be used to extract the DNS database discussed above.

Network Monitoring

Internet network monitoring serves three primary purposes:

- 1) Constant observation of the “health” of the network, network components, and external network connectivity. Standard Simple Network Management Protocol (SNMP) support is built-in to most active components today. Even network servers and workstations can be monitored in this way. Operations staff can be provided with network monitoring stations that will display alerts immediately upon detecting a wide variety of problems or anomalies;
- 2) Collection of statistics on the performance of the network and patterns of traffic in order to identify needed enhancements or re-engineering. Using the same SNMP capabilities mentioned above, data on packet forwarding and total traffic volume can be collected and used to generate periodic reports on network utilization;
- 3) More rapid problem resolution. When problems do occur, SNMP tools can help to pinpoint the source of the problem(s). Such problems include transient routing anomalies, DNS query failures, or even attempts at breaking into network accessible host computers.

Since network management and monitoring is a technically demanding task and requires special equipment and software, it should be a centralized function in the initial design of school network systems, as discussed above.

Summary

The model for school network implementation described above is based on broad experience with this technology in higher education and administrative

environments. Many schools have already installed networks very similar to this model. We believe that it is a practical first step towards bringing a powerful resource to bear for enriching all of the nation's school programs.

None of the suggestions above preclude or postpone in any way future development of an integrated voice, data, and video network for the nation's schools. Use of existing Internet carriers does not in any way preclude future development of a separate "backbone" for the K-12 community if such a "backbone" is determined to be cost effective or required for enhanced functionality. Rather, the infrastructure recommended above can be the foundation at the local level in preparation for future high capacity networks.

IV. Network Support

The installation of a campuswide network or Internet connectivity will also require a commitment to ongoing network support and its related resource requirements. There are two major areas of network support, network operations and user services. These support functions are usually performed through the establishment of a Network Operations Center (NOC) and Network Information Center (NIC), however both functions can be performed by the same individual or groups of individuals.

Network Operations Center (NOC)

The Network Operations Center (NOC) oversees the performance of the physical network and some of its software support systems. The staff may install networks, configure network devices and provide configurations for computers attached to an organization-wide network. Real-time monitoring of the network can be performed using the Simple Network Management Protocol and many vendors produce monitoring systems that graphically display network performance, log events and usage, and produce trouble tickets. The use of this type of network monitoring allows NOC staff to quickly detect problems and greatly reduces the personnel required to perform this function. Routine monitoring of the network can help to anticipate problems before they develop and lead to reconfigurations and upgrades as indicated. If problems do arise, NOC personnel may go on-site to troubleshoot a problem and repair it. If the problem is not local, NOC personnel will work with school district, County or regional network technical staff to resolve the problem.

NOC personnel also assign addresses to network computers and devices and maintain the Domain Nameservice (DNS) for their organization. Domain Nameservice is a machine registry service that runs on a network server and enables access to machines by easy to remember names, rather than a network number. DNS is required for any organization connected to the Internet and critical to the establishment of an electronic mail system.

It is most cost effective to have the Network Operation Center serve an entire organization or region. In order to ensure timely service all the way out to the most remote LAN, it is recommended that an organization assign local area network administration duties to on-site personnel to interact with NOC staff and assist with the maintenance of the network. In the case of a school

district, administrative support staff, teachers, librarians or school based technical staff can each take responsibility for a LAN or group of LANs. If a problem arises, it can be reported to the LAN administrator. The LAN administrator can determine if the problem is local or remote and if NOC staff need to be notified. If so, the LAN administrator acts as the single point of contact for the NOC to provide a good communications channel for information and ensure efficient coordination of problem resolution. This method of delegating responsibility provides for a high level of service for each LAN and optimally uses the time of NOC staff to provide economies of scale.

Network Information Center (NIC)

The Network Information Center (NIC) provides information and support services to facilitate the use of the network. The NIC often provides a help-desk service to answer questions about use of the network, references to useful resources and training in new tools or applications. The NIC may also provide services such as an on-line directory of network users and their electronic mail addresses, bulletin board services of information and notices about the network and on-line training materials. These NIC services could be provided on a school district or County level. Most of the information would not be site specific and can be delivered electronically using electronic mail, electronic conferencing, on-line bulletin boards or other document delivery mechanisms. These types of services may be well suited for a school or school district librarian.

Other types of support services may be performed by NIC personnel such as maintenance of the electronic mail system or Postmaster duties, coordination of an on-line bulletin board or campuswide information system (CWIS) and management of an on-line conferencing system. These duties are more technical in nature and will require technical staff to maintain them.

Postmaster

Every organization which uses electronic mail should have an Electronic Mail Postmaster and a mailbox, postmaster, for the receipt of messages regarding use of the electronic mail system, mail problems and general inquiries about reaching people within the organization. The Postmaster is responsible for reading postmaster mail and responding to inquiries. These duties can be performed by non-technical staff with forwarding of messages to the appropriate technical support person as required.

CWIS Administrator

Campuswide information systems or bulletin boards are one of the most useful applications on the network. These systems allow people to share timely notices, documents and other resources with large groups of people. These systems typically provide a hierarchical or tree like structure of menus that lead to on-line documents or other services. Common types of information include deadline notices, grant announcements, training schedules, lists of available resources such as videos in a library or reference materials.

Information need not be stored all in one location. Figure 7 shows a set of distributed servers. These servers can receive new information automatically from a central server and can also contain information generated locally that may pertain only to the local school. Users of the information need not know where the information is stored: the information access software will present choices on an integrated menu.

A CWIS or bulletin board must have an administrator or sponsor to oversee the design and maintenance of the system so that it is easy to navigate and find information, provides a professional presentation of information and ensures that information remains timely and relevant. This function can be performed by NIC staff, or trained librarians or administrative staff as appropriate.

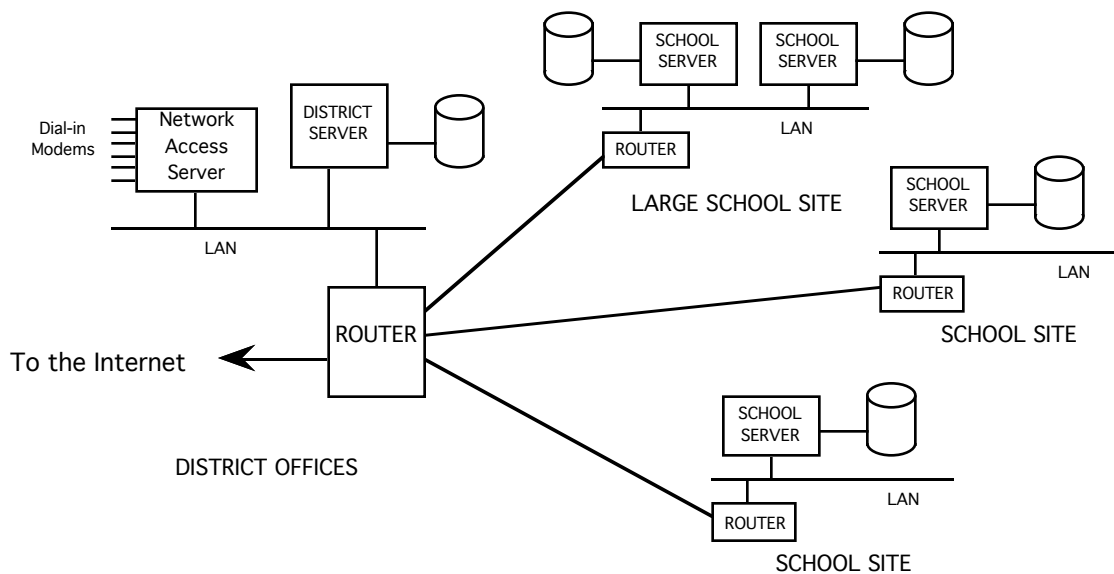

Figure 7. Distributed Network Information Servers

Management of On-line Conferences

On-line conferences provide a way for groups of people to share information, discuss ideas and pose questions. Conferences usually are set up to serve the needs of a group of people sharing a common interest. For example, an on-line conference might be established for teachers to discuss a new science teaching framework or a teacher may establish a conference for the discussion of the Civil War as part of an American History class. Some conferences are on-going and may exist for years. Others are short term and may exist for only one semester. Conferences may be created using the electronic mail system or a facility called Usenet News.

On-line conferencing systems require a server computer on the network that collects messages posted to a conference and distributes them when requested. Usually these systems are managed by a systems administrator and someone must configure the system to establish and delete groups upon request. Other management duties include scheduling the deletion of old

messages and archiving especially valuable conversations. Typically these duties are performed by a systems administrator or technical staff.

Staffing Considerations

The duties described above do not necessarily require hiring new staff and they may be shared by people already within an organization. Small schools or districts may rely on County Office of Education Information Systems staff to perform all functions. Larger schools or districts may have staff to take on any combination of duties and rely on the County Office of Education for others. Access to the network and the use of electronic communications allows people throughout the organization to perform these functions remotely. The assignment of responsibility for any of these duties is flexible and should be approached with the goal of providing the highest quality of service in the most cost effective and workable manner.

V. References

Honey, Margaret, Henriquez, Andres, "Telecommunications and K-12 Educators: Findings from a National Survey", Bank Street College of Education, New York, NY, 1993.

Susan Estrada, "Connecting to the Internet", O'Reilly & Associates, Inc. (ISBN 1-56592-061-9)

Carole Teach, editor, "Building the Future: K-12 Network Technology Planning Guide", California Department of Education, Research, Evaluation & Technology Division, 1994.

VI. Special Thanks

Special thanks to Brian Lloyd of Lloyd Internetworking, Inc. for his contributions to this document. Brian was one of the contributors to the California Department of Education "K-12 Network Technology Planning Guide" which served as the motivation for writing most of this document. Brian contributed significantly to Section II, "Rationale for the Use of Internet Protocols" and thoroughly reviewed Section III, "A Technical Model for School Networks", providing valuable feedback.

VII. Security Considerations

Security issues are not discussed in this memo.

VIII. Authors Addresses

Joan C. Gargano
Information Technology
Distributed Computing Analysis and Support
University of California
Davis, CA 95616

Email: jcgargano@ucdavis.edu

David L. Wasley
Data Communication & Network Services
Information Systems and Technology
University of California
Berkeley, CA 94720

Email: dlw@berkeley.edu